

The Sky Is the LimitSM

ROTAX
AIRCRAFT ENGINES

Operators Manual for Engine Types



ROTAX® 447 UL SCDI

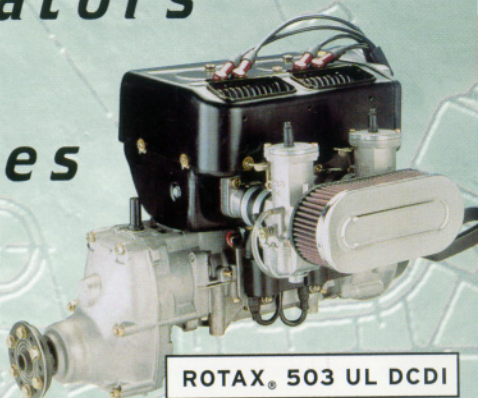

ROTAX® 503 UL DCDI

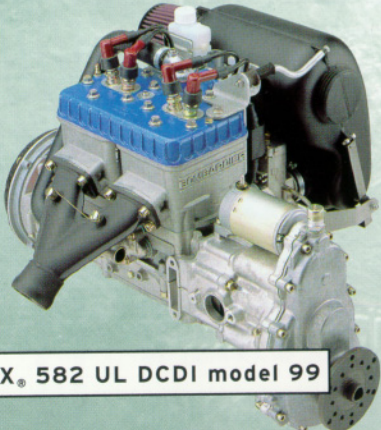

ROTAX® 582 UL DCDI model 99

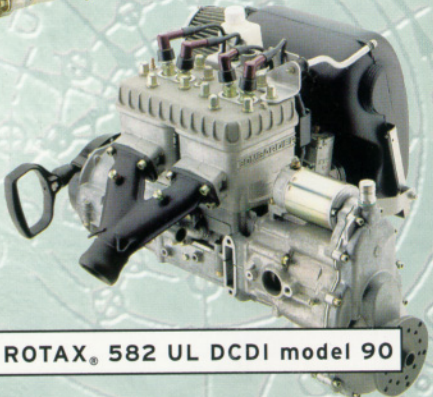

ROTAX® 582 UL DCDI model 90

Courtesy of Bomar Flying Service
www.bomar.biz

These technical data and the information contained therein are property of ROTAX® GmbH and must not be reproduced, neither in entirety nor partially, and passed on to third parties without previous consent in writing by ROTAX® GmbH. This text must be written on every complete or partial reproduction. The manual must remain with the engine / aircraft in case of sale.

▲ WARNING

Before starting the engine, read the Operators Manual. Failure to do so may result in personal injuries including death. Consult the original equipment manufacturer's handbook for additional instructions!

Approval of translation to best knowledge and judgement - in any case the original text in German language is authoritative.

1)	table of contents	1 - 2
2)	Index	2 - 1
3)	Introduction	3 - 1
	3.1) Remarks	3 - 2
	3.2) Engine serial number	3 - 2
4)	Safety	4 - 1
	4.1) Repeating symbols	4 - 1
	4.2) Safety information	4 - 2
	4.3) Technical documentation	4 - 6
5)	Index of pages	5 - 1
6)	List of amendments	6 - 1
7)	Description of design	7 - 1
	7.1) 447 UL SCDI, 503 UL DCDI	7 - 1
	7.2) 582 UL DCDI and 582 UL DCDI mod. 99:	7 - 2
	7.3) Type description:	7 - 3
	7.3.1) For 503 UL DCDI, 447 UL SCDI	7 - 3
	7.3.2) For ROTAX 582 UL DCDI	7 - 3
	7.3.3) For ROTAX 582 UL DCDI mod. 99	7 - 3
	7.4) Engine views:	7 - 4
	7.4.1) 447 UL DCDI	7 - 4
	7.4.2) 503 UL DCDI	7 - 5
	7.4.3) 582 UL DCDI and 582 UL DCDI mod. 99	7 - 6
8)	Technical data	8 - 1
	8.1) Dimensions	8 - 1
	8.2) Weights	8 - 1
	8.3) Fuel consumption	8 - 2
	8.4) Direction of rotation	8 - 2
9)	Description of systems	9 - 1
	9.1) Cooling system	9 - 1
	9.1.1) Cooling system of ROTAX 447 UL SCDI and of ROTAX 503 UL DCDI	9 - 1
	9.1.1.1) Free air cooling	9 - 1
	9.1.1.2) Fan cooling	9 - 1
	9.1.2) Cooling system of the ROTAX 582 UL DCDI	9 - 2
	9.1.3) Cooling system of the ROTAX 582 UL DCDI mod. 99	9 - 3
	9.2) Fuel system	9 - 4
	9.3) Lubrication system	9 - 5
	9.3.1) Lubrication	9 - 5
	9.3.2) Oil injection lubrication of ROTAX 503 UL DCDI, 582 UL DCDI and 582 UL DCDI mod. 99	9 - 5
	9.3.3) Lubrication of the rotary valve drive at 582 UL DCDI and 582 UL DCDI mod. 99	9 - 6

9.3.4)	Gearbox lubrication	9 - 6
9.4)	Electric system	9 - 7
9.5)	Propeller gearbox	9 - 8
9.5.1)	Type "B" gearbox	9 - 8
9.5.2)	Type "C" gearbox	9 - 8
9.5.3)	Type "E" gearbox	9 - 8
10)	Operating parameters	10 - 1
10.1)	Performance graphs for stand. conditions (ISA)	10 - 3
10.2)	Operating media	10 - 7
10.2.1)	Coolant	10 - 7
10.2.2)	Fuel	10 - 8
10.2.3)	Lubricants	10 - 10
10.3)	Standard operation	10 - 11
10.3.1)	Before engine start	10 - 11
10.3.2)	Daily checks	10 - 12
10.3.3)	Pre-flight checks	10 - 13
10.3.4)	Engine start	10 - 14
10.3.5)	Prior to take-off	10 - 15
10.3.6)	Checking of ignition unit (not possible for 447 UL SCDI)	10 - 15
10.3.7)	Operation in flight	10 - 15
10.3.8)	Special operating conditions:	10 - 16
10.4)	Abnormal operation	10 - 18
10.4.1)	Engine stop - Start during flight	10 - 18
10.4.2)	Exceeding of max. admissible engine speed	10 - 18
10.4.3)	Exceeding of max. admissible cyl. head temperature ..	10 - 18
10.4.4)	Exceeding of max. admissible exhaust gas temperature ..	10 - 18
10.4.5)	Too low fuel pressure	10 - 18
11)	Checks	11 - 1
11.1)	Engine preservation	11 - 1
11.1.1)	After each flight	11 - 1
11.1.2)	At engine stoppage of 1 to 4 weeks	11 - 1
11.1.3)	At out of service periods or storage of engine for longer than 4 weeks up to 1 year	11 - 2
12)	Trouble shooting	12 - 1
13)	ROTAX[®] authorized Distributors	13 - 1
14)	Warranty	14 - 1
14.1)	Warranty Conditions / Warranty Card	14 - 1
14.2)	Reporting	14 - 6

00682

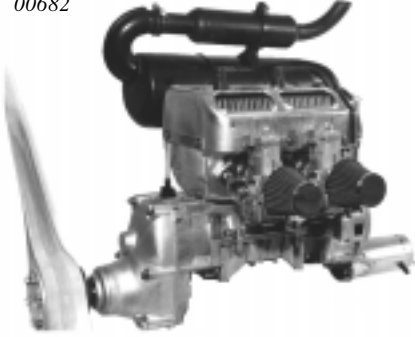

ROTAX 447 UL SCDI

00412



ROTAX 503 UL DCDI

03166

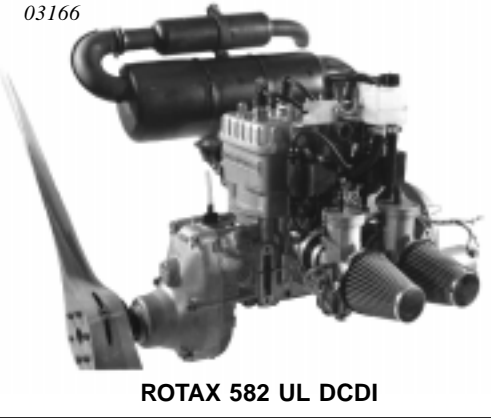

ROTAX 582 UL DCDI

03168



ROTAX 582 UL DCDI model 99

2) Index

A

Abnormal operation 10 - 18

C

Carburetor icing 10 - 16
Checking of ignition 10 - 15
Checks 11 - 1
Coolant 10 - 7
Cooling system 9 - 1, 9 - 2
Cylinder head temperature 10 - 1

D

Daily checks 10 - 11, 10 - 13
Denomination of cylinders 7 - 4
Description of design 7 - 1
Dimensions 8 - 1
Direction of rotation 8 - 2
Dry spark plugs 10 - 14

E

Electric system 9 - 7
Engine lubrication 10 - 10
Engine start 10 - 11, 10 - 14
Engine stop 10 - 18
Engine stoppage of 1 to 4 weeks 11 - 1
Exceeding of max. admissible cyl. head temperature 10 - 18
Exceeding of max. admissible engine speed 10 - 18
Exceeding of max. admissible exhaust gas temperature 10 - 18
Exhaust gas temperatures 10 - 1

F

Fan cooling 9 - 3
Free air cooling 9 - 3
Fuel 10 - 8
Fuel consumption 8 - 2
Fuel system 9 - 4

G

Gearbox lubrication 9 - 6, 10 - 10

H

High air humidity 10 - 16

I

Index 2 - 1
Index of pages 5 - 1
Introduction 3 - 1

L

List of amendments 6 - 1
Lubricants 10 - 10
Lubrication 9 - 5

M

Mixing procedure 10 - 9
Mixture lubrication 10 - 10

N

Noise 10 - 16

O

Oil capacity 10 - 1
Oil injection lubrication 9 - 5, 10 - 10
Operating media 10 - 7
Operating parameters 10 - 1
Operation in flight 10 - 15

P

Performance graphs 10 - 3
Pre-flight checks 10 - 11, 10 - 12
Preservation 11 - 1
Propeller gearbox 9 - 8

R

Rotary valve drive 9 - 6
Rotary valve drive lubrication 10 - 10
ROTAX® authorized Distributors 13 - 1

S

Safety 4 - 1
Safety information 4 - 2
Special operating conditions 10 - 16
Start 10 - 11
Start during flight 10 - 18
Storage of engine for longer than 4 weeks up
to 1 year 11 - 2
Systems 9 - 1

T

Technical data 8 - 1
Technical documentation 4 - 6
Too low fuel pressure 10 - 18
Trouble shooting 12 - 1
Type "B" 9 - 8
Type "C" 9 - 8
Type description 7 - 3
Type "E" 9 - 8

W

Warranty 14 - 1
Warranty Card 14 - 1
Warranty Conditions 14 - 1
WARRANTY REGISTRATION CARD 14 - 2
Water 10 - 16
Water in fuel 10 - 16
Weights 8 - 1
Wet spark plugs 10 - 14
Winter 10 - 16

3) Introduction

Congratulations on your decision to use a ROTAX[®] aircraft engine.

Before operating the engine, carefully read this Operator's Manual. The Manual provides you with basic information on the safe operation of the engine.

If any passages of the Manual are not understood or in case of any questions, please, contact an authorized Distribution- or Service Center for ROTAX[®] aircraft engines.

We wish you much pleasure and satisfaction flying your aircraft with this ROTAX[®] engine.

3.1) Remarks

This Operator's Manual is provided to familiarize the owner/user of this aircraft engine with basic operating instructions and safety information.

For more detailed maintenance, safety and flight information, consult the documentation provided by the aircraft manufacturer and dealer.

For further information on maintenance and spare parts service, contact the nearest ROTAX[®] distributor (see Chapter 13).

3.2) Engine serial number

On all enquiries or spare parts orders, always indicate the engine serial number, as the manufacturer makes product improvement modifications to the engine. The engine serial number should always be used when ordering parts to ensure correct part selection prior to shipment.

The engine serial number is located on the top of the crankcase, magneto side or ignition cover.

4) Safety

Although the mere reading of these instructions will not eliminate a hazard, the understanding and application of the information herein will promote the proper use of the engine.

The information and components-/system descriptions contained in this Operator's Manual are correct at the time of publication. ROTAX[®] however, maintains a policy of continuous improvement of its products without imposing upon itself any obligation to install them on its products previously manufactured.

ROTAX[®] reserves the right at any time to discontinue or change specifications, designs[®], features, models or equipment without incurring obligation.

The illustrations in this Manual show the typical construction. They may not represent in full detail or the exact shape of the parts which have the same or similar function.

Specifications are given in the SI metric system with the USA equivalent in parenthesis. Where precise accuracy is not required, some conversions are rounded off for easier use.

This document has been translated from the German language and the original German text shall be deemed authoritative.

4.1) Repeating symbols

This Manual uses the following symbols to emphasize particular information:

- ▲ **WARNING:** Identifies an instruction which, if not followed, may cause serious injury including the possibility of death.
- **ATTENTION:** Denotes an instruction which, if not followed, may severely damage the engine or other component.
- ◆ **NOTE:** Indicates supplementary information which may be needed to fully complete or understand an instruction.

4.2) Safety information

▲ **WARNING:** This engine, by its design, is subject to sudden stoppage. Engine stoppage can result in crash landings, forced landings or no power landings. Such crash landings can lead to serious bodily injury or death

▲ **WARNING:** This is not a certificated aircraft engine. It has not received any safety or durability testing, and conforms to no aircraft standards. It is for use in experimental, uncertificated aircraft and vehicles only in which an engine failure will not compromise safety.

User assumes all risk of use, and acknowledges by his use that he knows this engine is subject to sudden stoppage.

▲ **WARNING:** Never fly the aircraft equipped with this engine at locations, airspeeds, altitudes, or other circumstances from which a successful no-power landing cannot be made, after sudden engine stoppage.

Aircraft equipped with this engine must only fly in DAYLIGHT VFR conditions.

- This engine is not suitable for acrobatics (inverted flight, etc.).
- It should be clearly understood that the choice, selection and use of *this* particular engine on any aircraft is at the sole discretion and responsibility of the aircraft manufacturer, assembler and owner/user.
- Due to the varying designs, equipment and types of aircraft, ROTAX[®] grants no warranty or representation on the suitability of its engine's use on any particular aircraft. Further, ROTAX[®] grants no warranty or representation of this engine's suitability with any other part, component or system which may be selected by the aircraft manufacturer, assembler or user for aircraft application.
- Whether you are a qualified pilot or a novice, complete knowledge of the aircraft, its controls and operation is mandatory before venturing solo. Flying any type of aircraft involves a certain amount of risk. Be informed and prepared for any situation or hazard associated with flying.

A recognized training program and continued education for piloting an aircraft is absolutely necessary for all aircraft pilots. Make sure you also obtain as much information as possible about your aircraft, its maintenance and operation from your dealer.

- You should be aware that any engine may seize or stall at any time. This could lead to a crash landing and possible severe injury or death. For this reason, we recommend strict compliance with the maintenance and operation and any additional information which may be given to you by your dealer.
- Respect all government or local rules pertaining to flight operation in your flying area. Fly only when and where conditions, topography, and airspeeds are safest.
- Select and use proper aircraft instrumentation. This instrumentation is not included with the ROTAX[®] engine package. Only approved instrumentation may be installed.
- Before flight, ensure that all engine controls are operative. Make sure all controls can be easily reached in case of an emergency.
- Unless in a run up area, never run the engine with the propeller turning while on the ground. Do not operate engine if bystanders are close.
- In the interest of safety, the aircraft must not be left unattended while the engine is running.

- Keep an engine log and respect engine and aircraft maintenance schedules. Keep the engine in top operating condition at all times. Do not operate any aircraft which is not properly maintained or has engine operating irregularities which have not been corrected.
- Keep an engine log and enter any unusual engine behaviour. Do not fly unless you have corrected a given problem and recorded the correction in the log.
- Since special tools and equipment may be required, engine servicing should only be performed by an authorized ROTAX[®] engine dealer or a qualified trained mechanic approved by the local airworthiness authority.
- To eliminate possible injury or damage, ensure any loose equipment or tools are properly secured before starting the engine.
- Never leave your aircraft or other vehicle unattended while the engine is running. If operated by someone else you could be sued even if the use was unauthorized by you.
- When in storage protect the engine and fuel system from contamination and exposure.
- Certain areas, altitudes and conditions present greater risk than others. The engine may require carburetor recalibration or humidity or dust/sand preventative equipment, or additional maintenance may be required.

Consult your aircraft dealer or manufacturer and obtain the necessary information, especially before flying in new areas.

- Never operate the engine and gearbox without sufficient quantities of lubricating oil.
- Periodically verify level of coolant at 582 UL and 582 UL mod. 99.
- Never exceed maximum rated r.p.m.
Allow the engine to cool at idle for several minutes before turning off the engine.
- Maintain your engine in top condition and assume it's going to quit running at any time. Leave yourself a way out in the event of unexpected failure.
- Never mix fuel in an enclosed area, or where fumes could reach an ignition point.

- Make sure all engine controls are operative, that you know ON and OFF positions of throttle and ignition, that they are easily accessible, and that you can operate them instinctively without hesitation.
- Never refuel if fuel could be spilled on hot engine components. Use only safety approved fuel containers and never transport fuel in an unsafe manner.
- Check engine suspension frequently as well as the drive components, fuel lines, wiring, and fuel and air filters.
- Check for fuel contamination, air cleaners, etc. Protect engine while not in use from any contamination entering fuel or carburetion system, but be sure to remove storage protection before starting engine.

4.3) Technical documentation

The information given in the

- ☞ Installation Manual
- ☞ Operator's Manual
- ☞ Maintenance Manual
- ☞ Spare parts List
- ☞ Service Informations

are based on data and experience that is considered applicable for professionals under normal conditions.

The fast technical progress and variations of installation might render present laws and regulations inapplicable or inadequate.

The illustrations in this Manual are mere sketches and show a typical arrangement. They might not represent the actual part in all its details but depict parts of the same or similar function. Therefore deduction of dimensions or other details from illustrations is not permitted.

All necessary documentation is available from the ROTAX Distribution- and Service Centers (see Chapter 13).

◆ **NOTE:** The Illustrations in this Operator's Manual are stored in a graphic data file and are provided with a consecutive irrelevant number.

This number (e.g. 00277) is of no significance for the content.

5) Index of pages

00522

Chapter	Page	Date	Chapter	Page	Date
1	cover page	1 - 1	9	9 - 1	99 05 01
		1 - 2		99 05 01	
		1 - 3		99 05 01	
		1 - 4		99 05 01	
2		2 - 1	10	9 - 5	99 05 01
		2 - 2		99 05 01	
3		3 - 1		9 - 6	99 05 01
		3 - 2		99 05 01	
4		4 - 1		9 - 7	99 05 01
		4 - 2		99 05 01	
		4 - 3		99 05 01	
		4 - 4		99 05 01	
		4 - 5		99 05 01	
		4 - 6		99 05 01	
5		5 - 1		9 - 8	99 05 01
		5 - 2		99 05 01	
6		6 - 1		10 - 1	99 05 01
		6 - 2		99 05 01	
7		7 - 1		10 - 2	99 05 01
		7 - 2		99 05 01	
		7 - 3		99 05 01	
		7 - 4		99 05 01	
		7 - 5		99 05 01	
		7 - 6		99 05 01	
8		8 - 1	11	10 - 3	99 05 01
		8 - 2		99 05 01	
			12	10 - 4	99 05 01
				10 - 5	99 05 01
			13	10 - 6	99 05 01
				10 - 7	99 05 01
				10 - 8	99 05 01
				10 - 9	99 05 01
				10 - 10	99 05 01
				10 - 11	99 05 01
				10 - 12	99 05 01
				10 - 13	99 05 01
				10 - 14	99 05 01
				10 - 15	99 05 01
				10 - 16	99 05 01
				10 - 17	99 05 01
				10 - 18	99 05 01
				11 - 1	99 05 01
				11 - 2	99 05 01
				12 - 1	99 05 01
				12 - 2	99 05 01
				13 - 1	99 05 01
				13 - 2	99 05 01
				13 - 3	99 05 01
				13 - 4	99 05 01

d/00294

Effectivity: 447 SCDI, 503 DCDI,
582 DCDI



OM
initial issue

page 5 - 1
May 01/99

Chapter	Page	Date	Chapter	Page	Date
14	14 - 1	99 05 01			
	14 - 2	99 05 01			
	14 - 3	99 05 01			
	14 - 4	99 05 01			
	14 - 5	99 05 01			
	14 - 6	99 05 01			
	14 - 7	99 05 01			

Curr. no.	Chap- ter	Pages	Date of modification	Note of approval	Date of approval by authority	Date of insertion	Marks / Signature

7) Description of design

7.1) 447 UL SCDI, 503 UL DCDI

2 cylinder in line two stroke engine, piston ported, air cooled cylinder heads and cylinders, fan or free air version.

Mixture lubrication and on the 503 oil injection lubrication as an **optional extra**.

Double (503) or single (447) ignition of a breakerless, magneto capacitor-discharge design

◆NOTE: 447 engine is only available with single ignition.

Carburation with one or two piston type carburetors.

One pneumatic fuel pump.

Propeller drive via flange connected gearbox with incorporated shock absorber.

Exhaust system.

Rewind starter.

Intergrated AC generator (12V 170 W) with external rectifier-regulator as **optional extra**.

Air filter.

Intake silencer, **optional extra**.

■ATTENTION: At refitting of this intake silencer the carburetor must be recalibrated by an authorized person.

After muffler, **optional extra**.

High Altitude Compensation kit (HAC), **optional extra**.

Electric starter, **optional extra**.

7.2) 582 UL DCDI and 582 UL DCDI mod. 99:

Two stroke engine, 2 cylinder in line with rotary valve inlet.

Liquid cooled cylinder head and cylinders.

Integrated water pump.

Mixture lubrication or oil injection lubrication.

Dual ignition of a breakerless magneto capacitor discharge design.

2 piston type carburetors.

1 pneumatic fuel pump.

Propeller drive via flange connected gearbox with incorporated torsional shock absorber.

Exhaust system: standard version (48 KW) or version of reduced noise emission (40 KW) as **optional extra only at 582 UL DCDI**.

Electric starter or rewind starter.

Integrated AC generator (12 V 170 W) with external rectifier-regulator as **optional extra**.

Air filter.

Intake silencer, **optional extra**.

■ **ATTENTION:** At refitting of this silencer the carburetor has to be newly calibrated by an authorized person.

After muffler, **optional extra**.

High Altitude Compensation kit (HAC), **optional extra**.

Electric starter, **optional extra**.

Radiator (one-piece or two-piece radiator set)

◆ **NOTE:** 582 UL 40 DCDI and 582 48 DCDI are not longer available. 582 UL DCDI mod. 99 is only available as 48 KW version.

7.3) Type description:

◆NOTE: The type designation is of the following composition.

7.3.1) For 503 UL DCDI, 447 UL SCDI

ROTAX UL

Type
(type)

Zündung
(ignition)

02929

e.g. ROTAX 503 UL DCDI

7.3.2) For ROTAX 582 UL DCDI

ROTAX 582 UL DCDI

Leistung
power output

02932

Power output: 40 KW or 48 KW

e.g. ROTAX 582 UL DCDI 48

7.3.3) For ROTAX 582 UL DCDI mod. 99

ROTAX 582 UL DCDI mod. 99

02977

7.4) Engine views:

7.4.1) 447 UL SCDI

PTO view

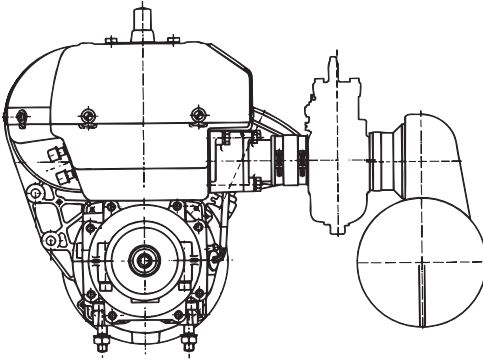

02781

fig. 1

lateral view

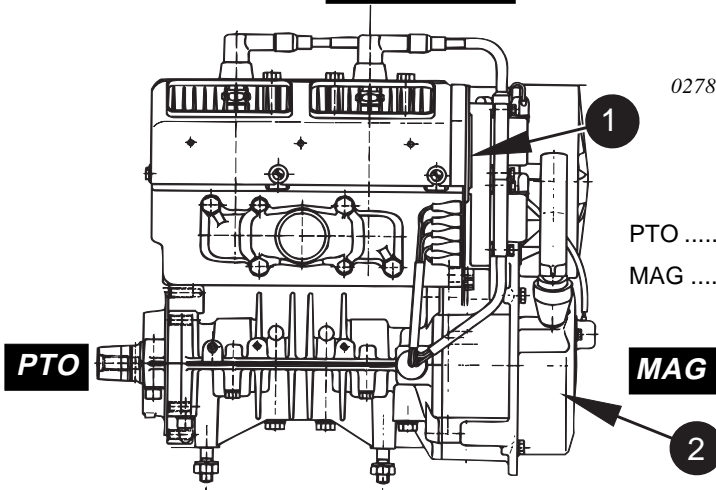

02782

PTO power take off side
MAG magneto side

PTO

MAG

(1) engine number

(2) rewind starter

fig. 2

◆ NOTE: Figure shows fan cooled version with intake silencer.

PTO view

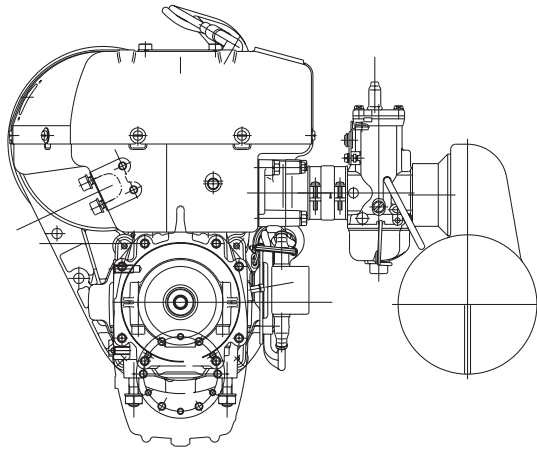

Courtesy of Bomar Flying Service
www.bomar.biz

lateral view

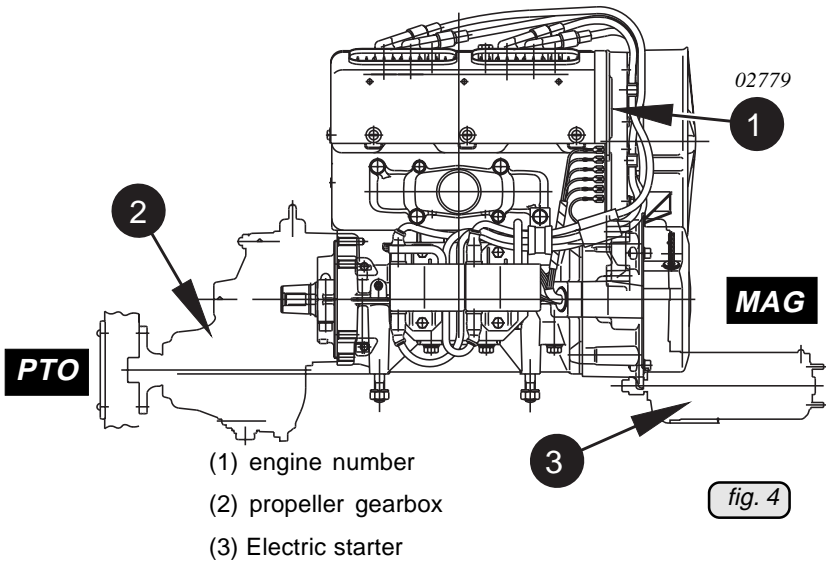

- (1) engine number
- (2) propeller gearbox
- (3) Electric starter

◆ NOTE: Figure shows fan cooled version with intake silencer.

7.4.3) 582 UL DCDI and 582 UL DCDI mod. 99

PTO view

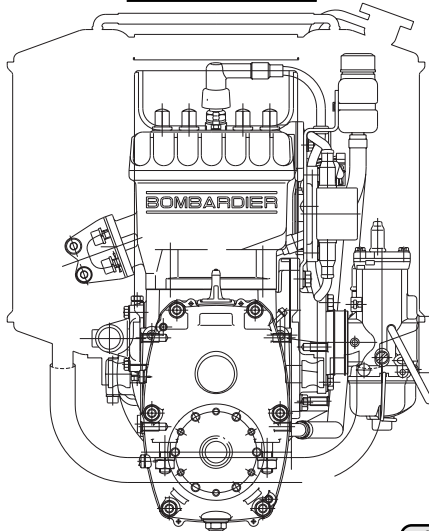

02042

fig. 5

lateral view

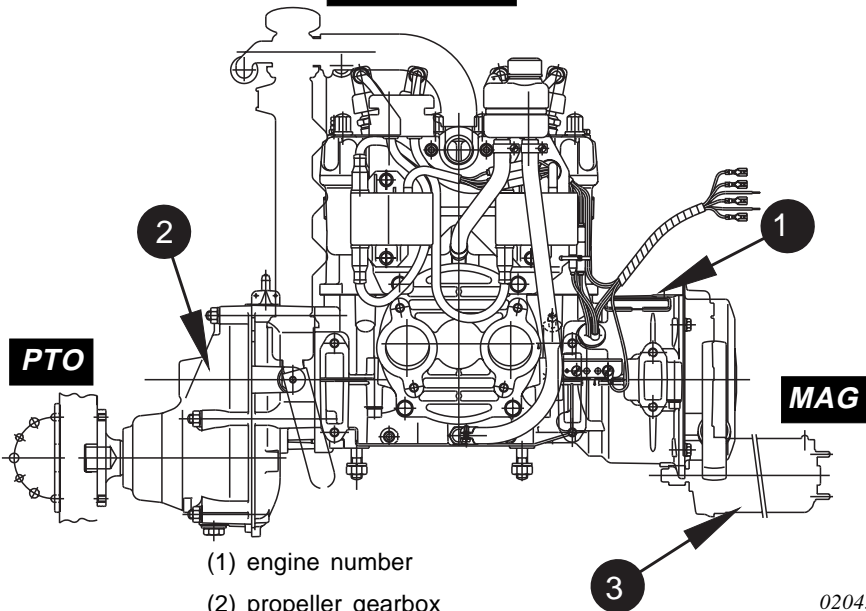

02043

fig. 6

- (1) engine number
- (2) propeller gearbox
- (3) Electric starter

◆ NOTE: Figure shows 582 UL DCDI engine with B-gearbox.

8) Technical data

8.1) Dimensions

description	447 UL SCDI		503 UL DCDI		582 UL DCDI / mod. 99	
bore	67,5 mm	(2,66 in)	72 mm	(2,84 in)	76 mm	(2,99 in)
stroke	61 mm	(2,4 in)	61 mm	(2,4 in)	64 mm	(2,52 in)
displacement	436,5 cm ³ (26,64 cu.in)		496,7 cm ³ (30,31 cu.in)		580,7 cm ³ (35,44 cu.in)	
comp. ratio theoretical	9,6 : 1		10,8 : 1		11,5 : 1	
comp. ratio effective	6,3 : 1				5,75 : 1	

02935

8.2) Weights

◆ NOTE: The stated weights are dry weights (without operating fluids)

without: exhaust system, radiator

Type	447 UL SCDI		503 UL DCDI		582 UL DCDI mod. 99		582 UL DCDI	
	kg	lb	kg	lb	kg	lb	kg	lb
Weight	26,8	59	31,4	69	29,3	64,6	27,4	60,4

02936

	447 UL SCDI		503 UL DCDI		582 UL DCDI / mod. 99	
	kg	lb	kg	lb	kg	lb
exhaust system	4,9	11	5,1	11,2	5,1	11,2
1 carburetor	0,9	2	0,9	0,9	0,9	2
"B" gearbox	4,5	9,9	4,5	9,9	4,5	9,9
"C" gearbox	8	17,6	8	17,6	8	17,6
"E" gearbox	11,2	24,6	11,2	24,6	11,2	24,6
Electric starter	3,5	7,7	3,5	7,7	3,5	7,7

02968

d00297

Effectivity: 447 SCDI, 503 DCDI,
582 DCDI



OM
initial issue

page 8 - 1
May 01/99

8.3) Fuel consumption

Fuel consumption in l/h (US gal/h)	447 UL SCDI	503 UL DCDI	582 UL DCDI mod. 99
at take-off performance	20 l/h (5,3 US gal/h)	25 l/h (6,6 US gal/h)	26,5 l/h (7 US gal/h)
at 75 % continuous performance	11 l/h (3 US gal/h)	15 l/h (4 US gal/h)	20,5 l/h (5,4 US gal/h)
specific fuel consumption	500 g/kWh (0,8 lb/hph)	550 g/kWh (0,9 lb/hph)	425 g/ kwh (0,7 lb/hph)

02969

8.4) Direction of rotation

Direction of rotation on propeller shaft: clockwise, looking at p.t.o. side of engine.

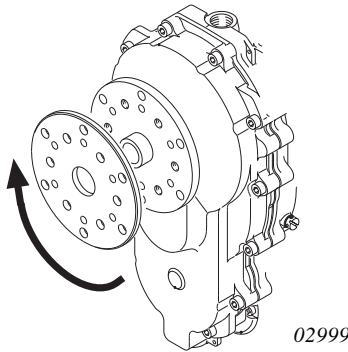

fig. 7

9) Description of systems

9.1) Cooling system

9.1.1) Cooling system of ROTAX 447 UL SCDI and of ROTAX 503 UL DCDI

Two versions of air cooling are available.

9.1.1.1) Free air cooling

Engine cooling by air-stream generated by aircraft speed and propeller.

9.1.1.2) Fan cooling

Cooling in air-stream generated by fan.

The fan is permanently driven from the crankshaft via a V-belt.

9.1.2) Cooling system of the ROTAX 582 UL DCDI

The cooling liquid is supplied by a integrated pump in the engine through the cylinders and the cylinder head to the radiator. The cooling system must be installed such that vapour coming from the cylinders and the cylinder head can escape to top via a hose either into the water tank of the radiator or to an expansion chamber.

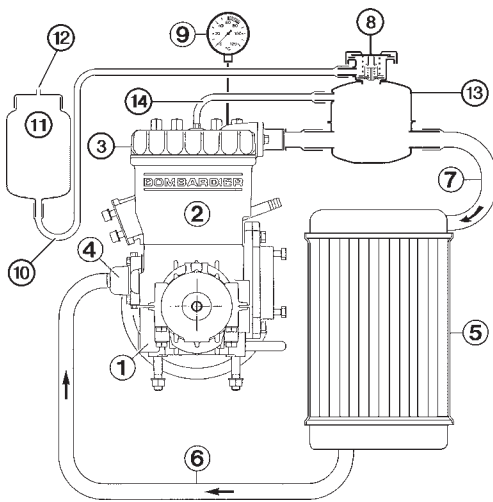

- 1 crankcase
- 2 cylinder
- 3 cylinder head
- 4 water pump
- 5 radiator
- 6 hose from radiator to water pump
- 7 hose from cylinder head to radiator
- 8 radiator screw cap, with excess pressure valve and return valve
- 9 temperature gauge for cooling water
- 10 overflow hose
- 11 overflow bottle
- 12 bottle venting
- 13 expansion tank
- 14 cylinder head venting hose

fig. 8

02044

9.1.3) Cooling system of the ROTAX 582 UL DCDI mod. 99

Engine cooling is performed by liquid cooled cylinder and cylinder head.

The cooling system is in a two circuit arrangement.

The cooling liquid is supplied by a integrated pump in the engine through the cylinders and the cylinder head to the radiator. The cooling system has to be installed such that vapour coming from the cylinders and the cylinder head can escape to top via a hose either into the water tank of the radiator or to an expansion chamber.

The expansion tank is closed by a pressure cap (with excess pressure valve and return valve). At temperature rise of the coolant the excess pressure valve opens and the coolant will flow via a hose at atmospheric pressure to the transparent overflow bottle. When cooling down, the coolant will be sucked back into the cooling circuit.

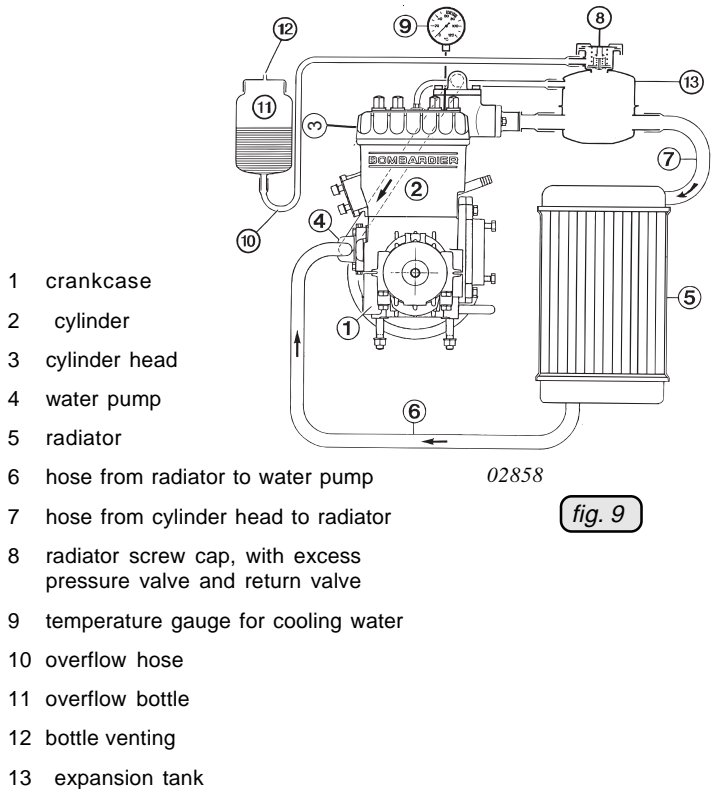

9.2) Fuel system

Generally, the engines are planned to run on a oil-gasoline mixture of 1 : 50. This mixture also supplies proper engine lubrication.

If the engine has been assembled for oil injection lubrication, the engine will be run on pure gasoline.

The integrated oil pump will deliver the exact amount of oil required for engine lubrication.

Make sure that adequate amount of oil is in the oil tank before putting engine into service.

◆ NOTE: For fuel refer to section 10.2.2.

9.3) Lubrication system

9.3.1) Lubrication

Generally the engines are designed to run on a mixture of gasoline and 2 % oil.

For preparation of fuel-oil mixture refer to section 10.2.2.

9.3.2) Oil injection lubrication of ROTAX 503 UL DCDI, 582 UL DCDI and 582 UL DCDI mod. 99

The oil pump (1) driven by the crankshaft (2) via the pump gear (3) (or via cross shaft at 582 UL DCDI and 582 UL DCDI mod.99) feeds the engine with fresh oil. The oil pump is a piston type pump with metering system. Via diffuser jets in the intake cover respectively intake socket each cylinder is supplied with exactly proportioned quantity of Super two-stroke oil. The oil quantity is defined by the engine r.p.m and the oil pump lever position. This lever is actuated via a Bowden cable connected to the throttle cable. The oil comes to the pump from an oil tank by gravity.

▲ **WARNING:** In case of fresh oil lubrication, the carburetors are fed with pure gasoline (no oil/gasoline mixture).

◆ **NOTE:** Figure shows version 503. Oil pump is driven by pump gear.

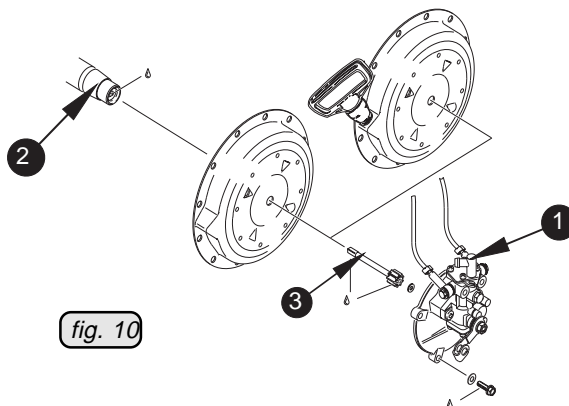

9.3.3) Lubrication of the rotary valve drive at 582 UL DCDI and 582 UL DCDI mod. 99

A 90° spiral gear situated in the crankcase and running in oil bath drives the rotary valve.

9.3.4) Gearbox lubrication

Gearbox lubrication operates with its own oil filled into gearbox housing.

Never operate engine with a dry gearbox.

◆ **NOTE:** For lubricants refer to section 10.2.3.

9.4) Electric system

The engine types 503 UL DCDI, 582 UL DCDI and 582 UL DCDI mod. 99 are equipped with a breakerless dual capacitor discharge ignition unit with integrated generator.

The engine 447 UL SCDI is equipped with a breakerless, single capacitor discharge ignition unit with integrated generator.

The ignition unit is completely free of maintenance and needs no external power supply.

Two charging coils fitted on the generator stator and independent from each other feed one each ignition circuit. The energy supplied is stored in the ignition capacitor. At the moment of ignition the external triggers supply an impulse to the control circuits and the ignition capacitors are discharged via the primary winding of the ignition coil. The secondary winding supplies the high voltage for the ignition spark.

◆ NOTE: The grey cable is planned for a rev-counter signal.

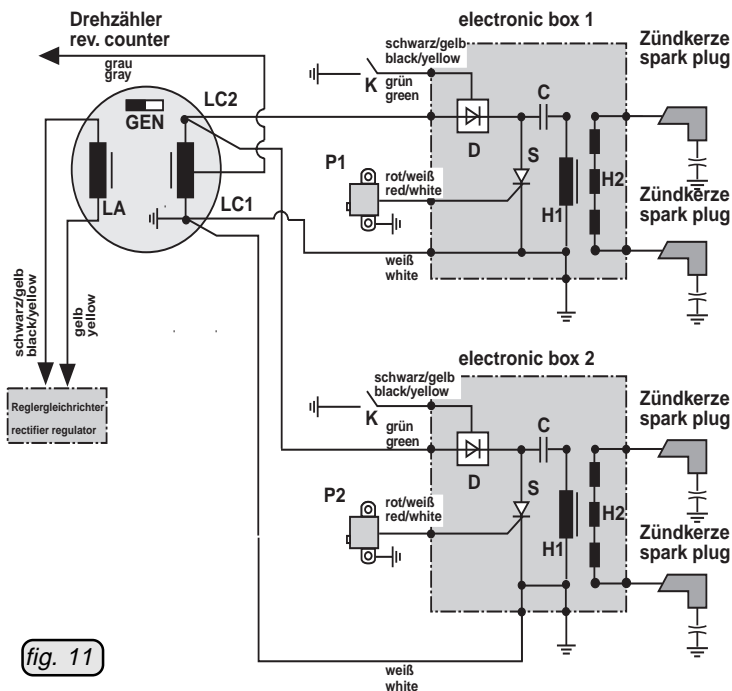

fig. 11

◆ NOTE: The lighting generator can also be incorporated in the gearbox EL or CL as an optional extra.

9.5) Propeller gearbox

There are three different gearboxes available as optional extras:

9.5.1) Type "B" gearbox

available gear ratios

crankshaft : propeller shaft	2,00 : 1
	2,24 : 1
	2,58 : 1

9.5.2) Type "C" gearbox

available gear ratios

crankshaft : propeller shaft	2,62 : 1
	3,00 : 1
	3,47 : 1
	4,00 : 1

◆ NOTE: This gearbox is not planned for 447 UL SCDI

◆ NOTE: This type of gearbox designated as CL is also available with an incorporated lighting generator.

9.5.3) Type "E" gearbox

available gear ratios

crankshaft : propeller shaft	2,62 : 1
	3,00 : 1
	3,47 : 1
	4,00 : 1

◆ NOTE: This gearbox is not planned for 447 UL SCDI

◆ NOTE: This type of gearbox designated as EL is also available with an incorporated lighting generator.

10) Operating parameters

1. Speed:

Take-off speed 6800 RPM max. 5 min
 Take-off speed at 582 UL DCDI 40 6400 RPM max. 5 min
 cruising speed 6500 RPM
 cruising speed at 582 UL DCDI 40 6000 RPM
 Idle speed ca. 2000 RPM

2. Take off Performance (ISA): (International Standard Atmosphere)

447 UL SCDI	503 UL DCDI	582 UL DCDI	582 UL DCDI mod. 99
29,5 kW	37 kW	40 kW	48 kW

02846

3. Oil capacity of oil injection lubrication at 1500 rpm pump speed per outlet

503 UL DCDI		582 UL DCDI / mod. 99	
cm ³ /h	cu.in/h	cm ³ /h	cu.in/h
max. 192	11,7	max. 135	8,2

02970

4. Cylinder head temperature (reading at spark plug seat):

dimension	447 UL SCDI		503 UL DCDI		582 UL DCDI / mod. 99	
	°C	°F	°C	°F	°C	°F
max.	260	500	250	480	150	300
normal	190-230	374-446	180-220	350 - 430	110 -130	230 - 270
difference between cyl. 1 and 2	max. 20	36	max. 20	34	max. 10	16

02971

5. Exhaust gas temperatures:

dimension	447 UL SCDI		503 UL DCDI		582 UL DCDI mod. 99	
	°C	°F	°C	°F	°C	°F
max.			650	1200	650	1200
normal			460-580	860-1000	500-620	930-1150
difference between cyl. 1 and 2			max. 25	43	max. 25	43

02972

- 6. Engine start, operating temperature:**
max. 50° C (120° F)
min. -25° C (- 13° F)
- 7. Coolant temperature on ROTAX 582 UL DCDI / mod. 99:**
max. 80° C (175° F)
min. 65° C (150° F)
- 8. Fuel pressure:**
max. 0,4 bar (6 psi)
min. 0,2 bar (3 psi)

10.1) Performance graphs for stand. conditions (ISA)

a) 447 UL SCDI

MOTORLEISTUNG / ENGINE PERFORMANCE

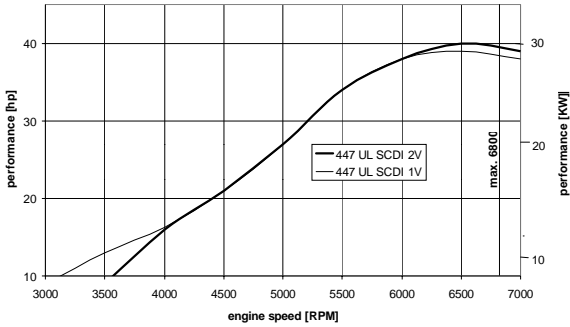

02789

fig. 12

MOTORDREHMOMENT / ENGINE TORQUE

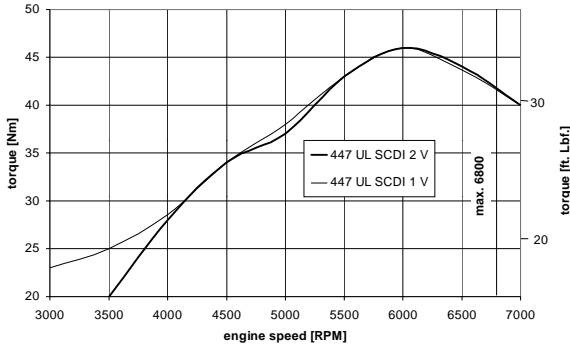

02788

fig. 13

TREIBSTOFFVERBRAUCH / FUEL CONSUMPTION

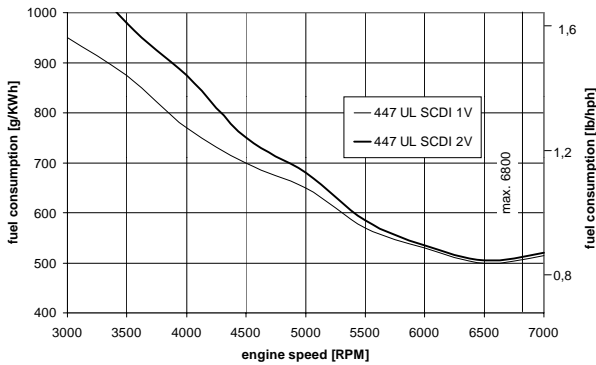

02787

fig. 14

d00308

b) 503 UL DCDI

MOTORLEISTUNG / ENGINE PERFORMANCE

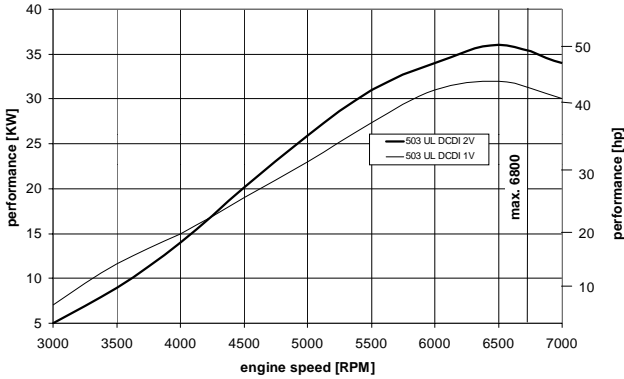

fig. 15

02786

MOTORDREHMOMENT / ENGINE TORQUE

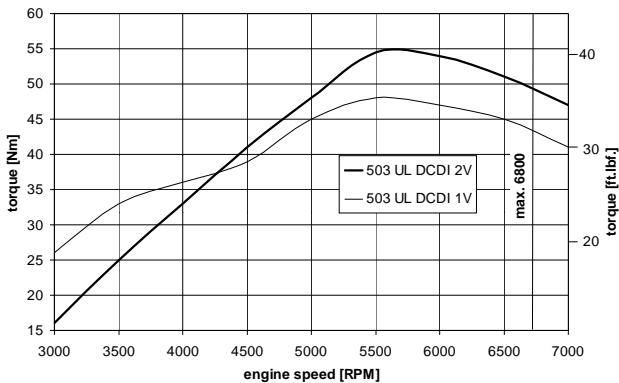

fig. 16

02785

TREIBSTOFFVERBRAUCH / FUEL CONSUMPTION

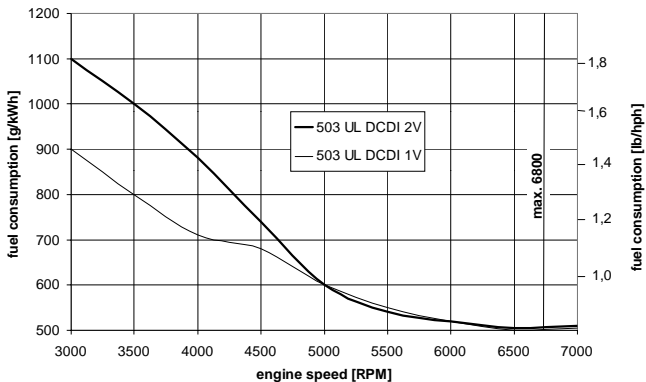
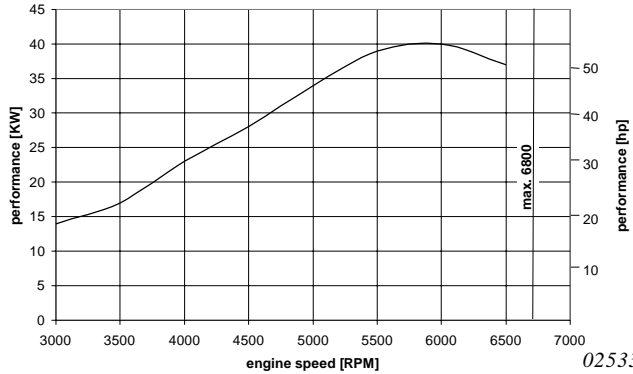

fig. 17

02784

c) 582 UL DCDI 40

MOTORLEISTUNG / ENGINE PERFORMANCE



MOTORDREHMOMENT / ENGINE TORQUE

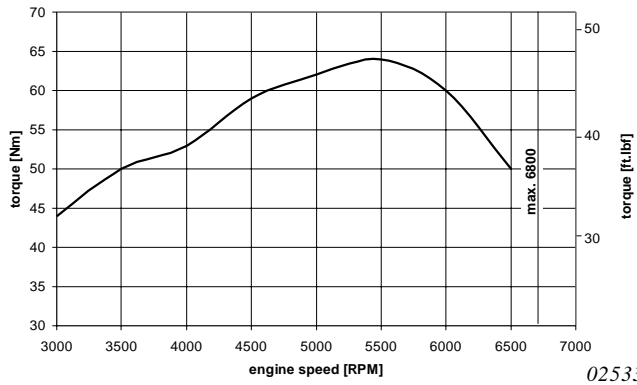

TREIBSTOFFVERBRAUCH / FUEL CONSUMPTION

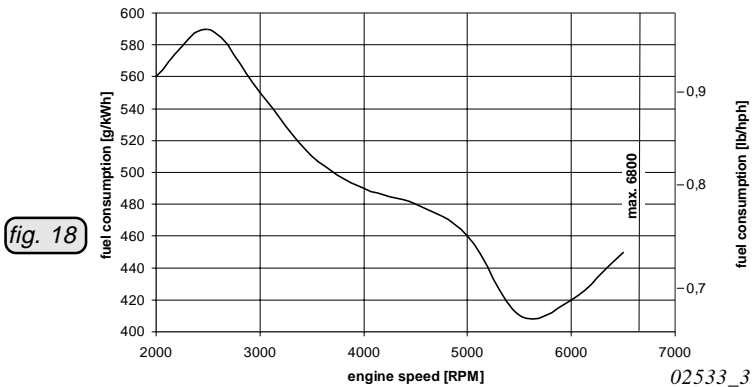

d) 582 UL DCDI 48 and 582 UL DCDI mod.99

MOTORLEISTUNG / ENGINE PERFORMANCE

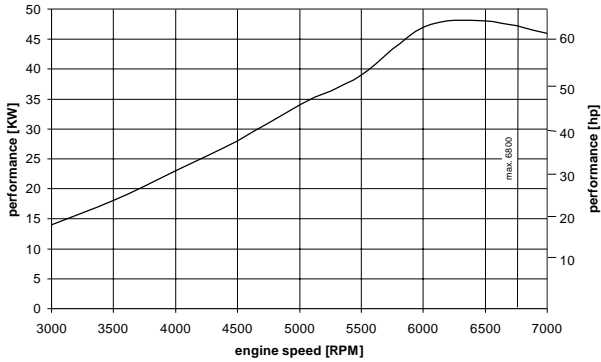

02532_1

MOTORDREHMOMENT / ENGINE TORQUE

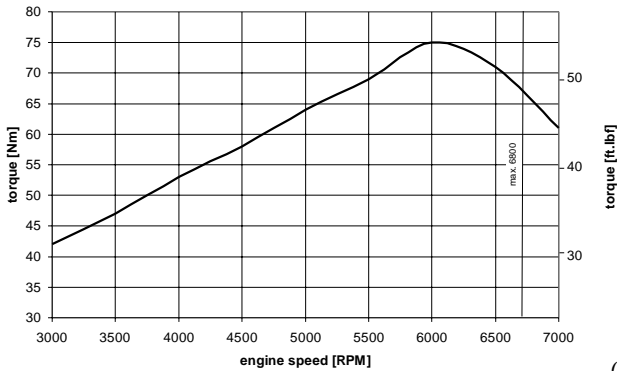

02532_2

TREIBSTOFFVERBRAUCH / FUEL CONSUMPTION

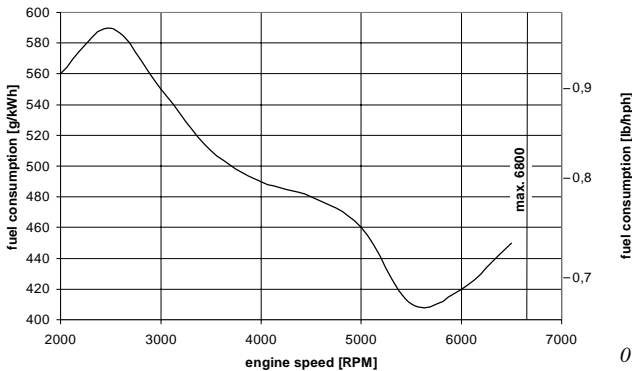

02532_3

fig. 19

10.2) Operating media

10.2.1) Coolant

Mixing ratio antifreeze / water

50 % antifreeze concentrate with additives against corrosion and 50 % pure water, or use of an equivalent premixed coolant.

■ **ATTENTION:** Take note of the specification from the antifreeze producer.

Satisfactory results were achieved with "BASF Glysantin Anticorrosion". Use this or an equivalent coolant.

◆ **NOTE:** If problems are encountered with boiling after engine stop increase percentage of antifreeze gradually.

In all cases, antifreeze to water ratios should not exceed the antifreeze manufacturer's recommendations. Exceeding the antifreeze manufacturers recommended ratios can lead to the formation of particulates in the coolant solution or inadequate protection against freezing.

■ **ATTENTION:** Particulate formation may be harmful to cooling system components and may restrict coolant flow to and from overflow bottle.

◆ **NOTE:** At verification of the coolant level replenish water in expansion tank. The coolant level in the overflow bottle should be between min. and max. mark.

10.2.2) Fuel

The following fuels can be used.

European standard	American standard	Canadian standard
min. RON 90		min AKI 87
EN 228 Regular	ASTM D 4814	CAN/CGSB-3,5
EN 228 premium		Quality 1
EN 228 premium plus		
AVGAS 100 LL		

03000

Due to higher lead content in AVGAS, the wear and deposits in the combustion chamber will increase. Therefore, use AVGAS only if you encounter problems with vapour lock or if the other fuel types are not available,

or

equivalent fuels according to this Chapter.

- **ATTENTION:** Use only fuel suitable for the relevant climatic conditions.
- ◆ **NOTE:** Risk of vapour formation in using winter fuel for summer operation.
- **ATTENTION:** If the engine is not equipped with injection lubrication a 2 % Super two stroke oil must be added to the fuel.

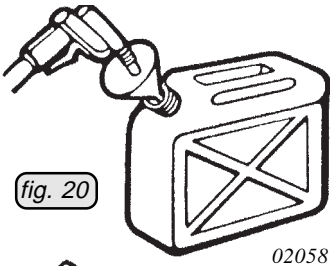

Mixing procedure

STEP no.1: Use a clean approved container of known volume. To help predilute the oil, pour a bit of fuel into the container.

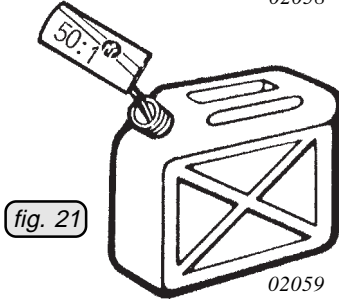

STEP no.2: Fill known amount of oil into container. Oil must be approved for air cooled engines at 50:1 mixing ratio. Agitate slightly to dilute oil with gasoline.

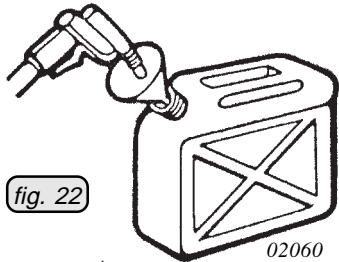

STEP no.3: Add gasoline to obtain desired mixture ratio (use fine mesh screen).

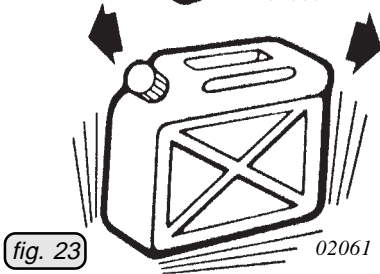

STEP no.4: Replace container cap and shake the container thoroughly. Then using a funnel with a fine mesh screen to prevent the entry of water and foreign particles, transfer mixture from container into the fuel tank.



▲ WARNING:

At refueling use only metal containers and ground the aircraft in accordance with the grounding specifications to avoid electrostatic charging.

10.2.3) Lubricants

a) Engine lubrication

1) Mixture lubrication: Super two stroke oil ASTM/CEC standards, API-TC classification (e.g. Castrol TTS) mixing ratio 1 : 50 (2%).

2) Oil injection lubrication (optional extra¹⁾):

Oil as specified above.

■ **ATTENTION:** The pour point of the oil must be at least 10°C below the ambient temperature.

b) Gearbox lubrication

Gear oil API-GL5 or GL6, SAE 140 EP,
or 85 W - 140 EP.

c) Rotary valve drive lubrication

Super two stroke oil (same as used for engine lubrication).

¹⁾ On 503 UL DCDI and 582 UL DCDI and 582 UL DCDI mod. 99.

10.3) Standard operation

To warrant reliability and efficiency of the engine, meet and carefully observe all the operating and maintenance instructions.

10.3.1) Before engine start

Carefully read and comply with the following guidelines:

- **Daily checks (section 10.3.2)**
- **Pre-flight checks (section 10.3.3)**
- **Start**

The life span of the engine depends to a great extent on compliance with these guidelines.

- ◆ **NOTE:** Prior to engine start verify that installation is complete and make sure that all engine controls are easily accessible and that you can operate them instinctively without hesitation.
- ◆ **NOTE:** Secure the area accordingly.

10.3.2) Daily checks

▲ **WARNING:** Repair as necessary all discrepancies and shortcoming before flight.

- Verify ignition "OFF".
- Drain water from fuel tank sump and/or water trap (if fitted).
- Inspect carburetor rubber socket or flange for cracks and verify secure attachment.
- Inspect carburetor float chamber for water and dirt.
- Verify security and condition of intake silencer and air filter.
- Verify security of radiator mounting. Inspect radiators for damage and leaks.
- Verify coolant level in overflow bottle and security of cap.
- Verify coolant hoses for security, inspect for leaks and chafing.
- Inspect engine for coolant leaks (cylinder head, cylinder base and water pump).
- Verify oil content for rotary valve gear lubrication and security of oil cap.
- Verify oil hoses for security, inspect for leaks and chafing (rotary valve gear lubrication system and oil injection system).
- Verify ignition coils / electronic boxes for secure mounting. Check ignition leads and all electrical wiring for secure connections and chafing.
- Verify electric starter for secure mounting, inspect cover for cracks.
- Verify engine to airframe mounting for security and inspect cracks.
- Verify fuel pump mounting for security. Inspect all fuel hose connections, filters, primer bulbs and taps for security, leakage, chafing and kinks.
- Verify fuel pump impulse hose for secure connections, inspect for chafing and kinks.
- Verify safety wiring of gearbox drain and level plugs.
- Inspect rubber coupling for damage and aging (C type gearbox only).
- Rotate engine by hand and listen for unusual noises (first double verify that ignition is OFF).
- Check propeller shaft bearing for clearance by rocking propeller.
- Inspect throttle choke and oil pump lever cables for damage (end fittings, outer casing and kinks).

10.3.3) Pre-flight checks

- ▲ **WARNING:** Repair as necessary all discrepancies and shortcoming before flight.
- Verify ignition "OFF".
 - Check fuel content.
 - Inspect for coolant leaks.
 - Verify oil tank content (oil injection engines).
 - Verify spark plug connectors for security.
 - Inspect engine and gearbox for oil leaks.
 - Inspect engine and gearbox for loose or missing nuts, bolts and screws. Verify security of gearbox to engine mounting.
 - Inspect propeller for splits and chips. If any damage, repair and/or rebalance before use.
 - Verify security of propeller mounting.
 - Check throttle, oil injection pump and choke actuation for free and full movement.
 - Verify that cooling fan turns when engine is rotated (air cooled engines).
 - Inspect exhaust for cracks, security of mounting, springs and hooks for breakage and wear, verify safety wiring of springs.
 - Start engine after assuring that area is clear of bystanders.
 - Single ignition engines - check operation of ignition switch (flick ignition off and on again at idling).
 - Dual ignition engines - check operation of both ignition circuits.
 - Check operation of all engine instruments during warm up.
 - If possible, visually check engine and exhaust for excessive vibration during warm up (indicates propeller out of balance).
 - Verify that engine reaches full power rpm during take off roll.

10.3.4) Engine start

▲ **WARNING!** Do not take the engine into operation if any person is near the aircraft.

On cold engine, apply choke fully. Ensure idle position of throttle valves as opening throttle will greatly reduce choke effect resulting in hard starting.

Make sure ignition switch is on and that you can shut it off instantly if necessary. Pull starter until firmly engaged and then pull smartly through.

■ **ATTENTION:** At employment of an electric starter, activate starter for max. 10 sec. only (without interruption), followed by a cooling period of 2 min.

Above procedure should be repeated until engine begins to "fire". As soon as engine starts, shift the throttle slowly to low speed and remove choke as soon as possible. Prolonged use of choke can cause engine to flood.

If the engine fails to start or operates only on one cylinder, check whether the ignition wiring is correctly connected to the spark plug connectors, check spark plugs and check the ignition is in ON position.

■ **ATTENTION:** Ensure grounding switch is in correct position and wired correctly.

10.3.5) Prior to take-off

Warming up period:

Start warming up period at 2000 engine r.p.m. for approx. 2 minutes, continue at 2500 r.p.m. until operating temperatures are reached.

- Verify that temperatures and pressures are in operational range prior to take off.

Throttle response:

- Short full throttle ground test (consult Aircraft Operator's Manual since engine speed depends on the propeller used).

■ **ATTENTION:** After a full-load ground test, allow a short cooling run to prevent vapour formation in the cylinder head.

10.3.6) Checking of ignition unit (not possible for 447 UL SCDI)

Before every flight or operation, the function of the two ignition systems must be checked. For checking the ignition unit the engine must be operated at 3000 to 3500 1/min and alternately ignition system 1 and 2 must be switched off. The RPM-drop must not exceed max. 300 1/min.

10.3.7) Operation in flight

It is recommended to use full throttle during take-off and climb, if not specified otherwise, slight throttle reduction may create a leaner mixture and should be avoided. Select a cruising speed where the engine is running smooth.

Do not exceed maximum engine rpm.

During cruise and descending it is very important not to create a lean condition with high rpm and low throttle opening. The less fresh charge the engine gets, the more hot residual gas remains in the cylinder. This raises the temperatures to a critical level. For this reason, you may also experience higher exhaust gas and cylinder head temperatures at reduced throttle openings.

Minimum engine idle speed is 2000 engine r.p.m. Higher idle r.p.m. setting will reduce enrichment action of starting circuit in carburetor (choke) making cold starting difficult.

Prior to shutdown, engine should be run until latent heat build-up from previous high power settings has been dissipated (approx. 3000 r.p.m. or at nearest smooth running r.p.m. for a minimum of two minutes followed by a short period of idle - 2000 r.p.m.).

Do not idle for prolonged periods as normal rich condition present at this power setting can cause unnecessary carbon deposits and spark plug fouling. Additional shock loads present at idle cause gear box, propeller, and/or drive train to operate in conditions which should be avoided whenever possible.

10.3.8) Special operating conditions:

Water:

There are dangers to your engine that you may not experience on land. Some of these dangers are water ingestion on take-off or landing due to spray and splash, corrosion, electrolysis, and, worst of all, unintentional submersion.

Bearings, crankshaft etc., are highly susceptible to corrosion. Synthetic oils, although good lubricants, often attract moisture rather than repel it.

A well designed and well maintained air intake system (e.g. ROTAX intake silencer with K & N oil impregnated air filter) will help to prevent water ingestion.

Noise:

The air intake silencer kit will provide significant engine noise reduction. Further noise reduction may be obtained by the use of an after-muffler kit. Be aware that modifications will require a different carburetor setting.

Enquire at your dealer for more information, and consult ROTAX.

Winter:

Winter can create additional problems such as carburetor icing, frozen fuel lines, higher air densities etc., which may affect carburetor calibration and require longer warm-up periods.

Carburetor icing:

Distinguish between two kinds of carburetor icing,

Icing due to water in fuel:

Water in fuel will accumulate at the lower parts of the fuel system and leads to freezing of fuel lines, filters or jets.

Icing because of high air humidity:

Carb icing due to humidity may occur on the fuel exit and on the carb piston and lead to performance loss by changes to the mixture.

Effective remedy is possible only by preheating intake air.

Remedies:

- Fuelling without traces of water (use shammy as filter).
- Generously sized water trap.
- Fuel line routing inclined.
- Prevent condensation of humidity, i.e. avoid temperature differences between aircraft and fuel.

■ **ATTENTION:** Fuels containing alcohol always carry a small amount of water in solution. In case of temperature changes or increase of alcohol content, water or a mixture of alcohol and water may settle and could cause troubles.

10.4) Abnormal operation

▲ **WARNING:** At unusual engine behaviour conduct checks as per Chapter 10.4.1) through 10.4.5) below, and according to the relevant section in the Maintenance Manual.

◆ **NOTE:** Further checks - see Maintenance Manual.

10.4.1) Engine stop - Start during flight

Starting procedure same as on ground, however, on a warm engine without choke.

10.4.2) Exceeding of max. admissible engine speed

Reduce engine speed. Any exceeding of the max. admissible engine speed must be entered by the pilot into the logbook, stating duration and extent of overspeed.

10.4.3) Exceeding of max. admissible cyl. head temperature

▲ **WARNING:** Reduce engine power setting to the minimum necessary and carry out precautionary landing.

Any exceeding of the max. admissible cylinder head temperature must be entered by the pilot into the logbook, stating duration and extent of excess-temperature condition.

10.4.4) Exceeding of max. admissible exhaust gas temperature

▲ **WARNING:** Reduce engine power setting to the minimum necessary and carry out precautionary landing.

Any exceeding of the max. admissible exhaust gas temperature must be entered by the pilot into the logbook, stating duration and extent of excess-temperature condition.

10.4.5) Too low fuel pressure

▲ **WARNING:** Reduce engine power setting to the minimum necessary and carry out precautionary landing.

▲ **WARNING:** Repair as necessary all discrepancies and shortcomings before next flight.

11) Checks

All checks to be carried out as specified in the current Maintenance Manual (last revision).

▲ **WARNING:** **Only qualified staff (experienced two stroke mechanics) trained on this particular engine, are allowed to carry out maintenance and repair work.**

■ **ATTENTION:** Carry out all directives of Service Informations, according to their **priority.**

11.1) Engine preservation

If the engine is not going to be used for a extended period of time, certain measures must be taken to protect engine against heat, direct sun light, corrosion and formation of residues.

In particular the water bonded by the alcohol in the fuel causes increased corrosion problems at engine stops or storage. Especially affected are essential engine components such as crankshaft bearings and conrod bearings as well as crank pins and piston pins.

11.1.1) After each flight

- Activate choke for a moment before stopping engine
- Close all engine openings like exhaust pipe, venting tube and air filter to prevent entry of contamination and humidity.

11.1.2) At engine stoppage of 1 to 4 weeks

- proceed with preservation prior to engine stop or on the engine at operating temperature.
- let the engine run at increased idle speed
- shut engine down and secure against inadvertent engine start
- remove air filters and inject approx. 3 ccm of preservation oil or equivalent oil into the air intake of each carburetor.
- restart engine and run at increased idle speed for 10 - 15 seconds
- shut engine down and secure against inadvertent engine start
- close all engine openings such as exhaust pipe, venting tube and air filter to prevent entry of contamination and humidity.

11.1.3) At out of service periods or storage of engine for longer than 4 weeks up to 1 year

- proceed with preservation prior to engine stop and on the engine at operating temperature
 - let the engine run at increased idle speed
 - remove air filters and inject approx. 6 cm³ of preservation oil or equivalent oil into the air intake of each carburetor
 - stop engine
 - remove spark plugs and inject approx. 6 ccm preservation oil or equivalent oil into each cylinder and slowly turn crankshaft 2 to 3 turns by hand to lubricate top end parts. Refit spark plugs.
 - drain gasoline from float chambers, fuel tank and fuel lines.
 - drain coolant on liquid cooled engines, to prevent any damage by freezing
- ▲ **WARNING:** Generally comply with standard rules for handling of chemicals. Dispose of chemicals as per local environmental regulations.
- Lubricate all carburetor linkages.
 - Close all openings of the engine like exhaust end pipe, venting tube and air intake to prevent entry of dirt and humidity.
 - spray all external steel parts with engine oil.

12) Trouble shooting

▲ WARNING: Only qualified staff (experienced two stroke mechanics) trained on this particular engine, are allowed to carry out maintenance and repair work.

If the following hints regarding remedy do not solve the problem, contact an authorized workshop. The engine must not be operated until the problem is rectified.

Your ROTAX engine requires basically two essentials to run. Spark and correct fuel/air mixture. The majority of problems quite often are a simple lack of one or the other.

Follow an organized method of troubleshooting. This will facilitate the identification of discrepancies or shortcomings.

Fuel: start by checking the supply (tank), fittings (loose?), filter (plugged?), float chamber (fouled?).

Spark: try new plugs.

Problems of a more complex nature are best left to a ROTAX engine technician: see your service center.

Engine keeps running with ignition off

POSSIBLE CAUSE:

a - overheating of engine

REMEDY:

let engine cool down at idling at approx. 2000 engine r.p.m.

Knocking under load

POSSIBLE CAUSE:

a - Octane rating of fuel too low

b - fuel starvation, lean mixture

REMEDY:

use fuel with higher octane rating.

check fuel supply.

13) ROTAX[®] authorized Distributors

for ROTAX[®] Aircraft Engines

Edition 1999 01 05

1) EUROPE

AUSTRIA:

► **HB - FLUGTECHNIK GES.M.B.H.**

Dr. Adolf Schärf Str. 44
A-4053 HAID
Tel.: 07229 / 79104/79117, Fax: 07229 / 79104
15

Contact person: Ing. Heino Brditschka

BULGARIA:

► **GERGANOV - AIRCRAFT ENGINES LTD.**

25B-Post 20, 23 peh. Shlp. polk Blvd.
BG-6100 KAZANLAK
Tel.: 431 / 27 247, Fax: 431 / 23 777

Contact person: Radosslav D. Gerganov

CROATIA / former YUGOSLAVIA (except SLOVENIA):

► **SHAFT D.O.O.**

B.L. Mandica 161 a
HR-54000 OSIJEK
Tel. + Fax: 031 / 280-046

Contact person: Ing. Ivan Vdovjak

CZECHIA:

► **TEVESO S.R.O.**

Skroupova 9441
CS-50002 HRADEC KRALOVE
Tel.: 049 / 56 30 127, Fax: 049 / 56 30 226
E-mail: teveso@mbox.vol.cz
Contact persons: Ing. Samal / Ing. Halek

DENMARK / THE NETHERLANDS:

► **FLIGHT-CENTER**

Flugplatz
D-27777 GANDERKESEE, GERMANY
Tel.: 04222 / 3789, Fax: 04222 / 6042
E-mail: flightcenter@olis.de
Contact person: Robert Heilig

FINLAND / NORWAY/ SWEDEN/ ESTONIA/ LATVIA / LITHUANIA

► **LYCON ENGINEERING AB**

Härkeberga, SE-74596 ENKÖPING
Tel.: 171 414039; FAX: 171 414116
E-mail: info@lycon.se
Contact person: Yard Johansson

FRANCE / BELGIUM / MONACO / LUXEMBURG:

► **MOTEUR AERO DISTRIBUTION**

11 Blvd Albert 1
98000 MONACO
Tel.: 7 93 30 17 40, Fax: 7 93 30 17 60
E-mail: mad.rotax@worldnet.fr
Contact person: Patrick Coyette

GERMANY:

for postcodes 0-5-6-7-8-9:

► **FRANZ AIRCRAFT ENGINES
VERTRIEB GMBH**

Am Eckfeld 6e, D-83543 ROTT AM INN
Tel.: 08039 / 90350, Fax: 08039 / 9035-35
E-mail: Franz-Aircraft.EF@t-online.de
Contact person: Eduard Franz

for postcodes 1-2-3-4:

► **FLIGHT-CENTER**

Flugplatz
D-27777 GANDERKESEE
Tel.: 04222 / 3789, Fax: 04222 / 6042
E-mail: flightcenter@olis.de
Contact person: Robert Heilig

GREAT BRITAIN / IRELAND / ICELAND:

► **SKYDRIVE LTD.**

Burnside, Deppers Bridge
LEAMINGTON Spa. CV 33 OSU
Tel.: 1926 / 612 188, Fax: 1926 / 613 781
E-mail: skydrive@avnet.co.uk
Contact person: Nigel Beale

GREECE / CYPRUS:

► **KINISI**

Ellis 1 str., GR-14563 KIFISSIA
Tel.: 01 / 620 8611; Fax: 01 / 625 0026
Contact person: Michael Poulikakos
Nick Siganos

HUNGARY:

► **HALLEY**

Baktai út 45, P.O. Box 425
H-3300 EGER
Tel.: 36 / 313-830, Fax: 36 / 320-208

ITALY / MALTA:

►ICARO MOTORI S.R.L.

Via Emilia, 61/B
I-27050 REDAVALLE (PV)
Tel.: 0385 / 74 591, Fax: 0385 / 74 592
E-mail: icaro@energy.it
Contact person: Corrado Gavazzoni

POLAND:

►FASTON LTD.

ul. Szeroka 2
PL-05-860 PLOCHOCIN
Tel.: 22 / 722-5858; Fax: 22 / 840-0196
Contact person: Wojtek Madry,
Manager

ROMANIA:

►S.C. BERIMPEX S.R.L.

Str. Dr. Taranu Grigore No. 8, Ap. 2, Sector 5
R-76241 BUCHAREST
Tel.: 1-410 90 03; Fax: 1-410 9020
E-mail: c_berar@sunu.ro
Contact person: Dr. Christian Berar

SLOVAKIA:

►TEVESO S.R.O.

Skroupova 441
CS-50002 HRADEC KRALOVE
Tel.: 049 / 56 30 127, Fax: 049 / 56 30 226
E-mail: teveso@mbox.vol.cz
Contact persons: Ing. Samal / Ing. Halek

SLOVENIA:

►PIPISTREL d.o.o.

Strancarjeva Ul. 11
5270 AJDOVSCINA
Tel. 065 63 873, Fax: 065 61 263
E-mail: pipistrel@eunet.si
Contact person: Ivo Boscarol

SPAIN / PORTUGAL:

►AVIASPORT S.A.

Almazara 11
E-28760 TRES CANTOS (MADRID)
Tel.: (91) 803 77 11, Fax: (91) 803 55 22
E-mail: aviaspor@bcnetwork.es
Contact person: Mariano de Castro

SWITZERLAND / LIECHTEN- STEIN:

►FRANZ AIRCRAFT ENGINES VERTRIEB GMBH

Am Eckfeld 6e, D-83543 Rott am Inn, GERMANY
Tel.: 08039 / 90350, Fax: 08039 / 9035-35
E-mail: Franz-Aircraft.EF@t-online.de
Contact person: Eduard Franz

TURKEY:

►KLASIK HALI A.S.

Klasik Hali is Merkezi, Bozkurt Caddesi No. 25/A
35230 Kapilar / IZMIR TURKEY
Tel.: (232) 441 4911; Fax: (232) 445 1285
Contact person: Tahir Önder, President

2) A M E R I C A

CANADA:

►ROTECH RESEARCH CANADA, LTD.

6235 Okanagan Landing Rd.
VERNON, B.C., V1H 1M5, Canada
Tel.: 250 / 260-6299, Fax: 250 / 260-6269
E-mail: inquiries@rotec.com
website: www.rotec.com

NORTH / MIDDLE / SOUTH AMERICA:

►KODIAK RESEARCH LTD.

P.O. Box N 7113
Marlborough House Cumberland Street
NASSAU, BAHAMAS
Tel.: 242 / 356 5377, Fax: 242 322 6784
E-mail: custsupport@kodiakbs.com
website: www.kodiakbs.com

3) A U S T R A L I A

►AIRCRAFT ENGINE DISTRIBUTORS PTY. LTD.

P.O. Box 84, Boonah, QLD. 4310
Tel.: 07 5463 2755, Fax: 07 5463 2987
E-mail: sales@austflight.com.au
Contact person: Jim Fenton

►BERT FLOOD IMPORTS PTY. LTD.

P.O. Box 61, LILYDALE, VICTORIA 3140
Tel.: 03 / 9735 5655, Fax: 03 / 9735 5699
E-mail: flood@smart.net.au
Contact person: Bert Flood

NEW ZEALAND:

►TIPPINS INTERNATIONAL

P.O. Box 192, Tuakau
SOUTH AUCKLAND
Tel.: 09 / 233 - 4898, Fax: 09 / 233 - 4798
E-mail: data@ets.co.nz
Contact person: Murray Tippins

4) AFRICA

EGYPT:

►AL MOALLA

P.O. Box 7787, ABU DHABI
Tel.: (2) 723 248, Fax: (2)788 073
E-mail: almoalla@emirates.net.ae
Contact person: Hussain Al Moalla

ANGOLA / BOTSWANA / LESOTHO / MADAGASCAR / MALAWI / MOZAMBIQUE / NAMIBIA / SOUTH AFRICA / SWAZILAND / ZAMBIA / ZIMBABWE:

►AVIATION ENGINES

ANDACCESSORIES (PTY) LTD

Private Bag X10021, Edenvale 1610, South Africa
Tel.: 011 / 455 4203/4/5/6/9, Fax: 011 / 455 4499
E-mail: flying@iafrica.com
Contact person: Mike Blyth

5) ASIA

CHINA / HONG KONG / MACAO:

►DUEN MU CO.

Flat A, 3/F, Kam Meng Fung
Industrial Building,
6 Hong Man Street, Chai Wan,
HONGKONG
Tel.: 2756 5725, Fax: 2754 4774
E-mail: cali@tfhtech.com
Contact person: W. C. Choi

CIS:

►AVIAGAMMA JSCo.

P.O. Box 51, 125 057 MOSCOW
Tel.: 095 / 158 31 23, Fax: 095 / 158 6222
E-mail: vkrag@city.line.ru
Contact person: Vladimir Andriytschuk
General Director

INDIA:

►GREAVES LIMITED

22-A, Janpath
NEW DELHI - 110 001
Tel.: 11/338 50 61/338 26 53 (Dir.), Fax: 11/37 82
553 Tlx.: 031-62663
E-mail:
greaves@GRVSDEL.XEEDEL.XEMAIL.com
Contact person: Wg Cdr S.N. Chhabra
Divisional Manager

INDONESIA / MALAYSIA / PHILIP- PINES / SINGAPORE / THAILAND / TAIWAN:

►TPA PTE LTD.

12 Little Road, #02-01/02
Lian Cheong Industrial Building
Singapore 536986
Tel.: (65) 289 8022
Fax: (65) 289 1011
E-mail: aviation@tpa.com.sg
Contact person: Chan Nyuk Lin

IRAN:

►H.F. DORNA CO.

P.O. Box 16315-345, Tehran
Tel.: 21 285 4827, Fax: 21 284 1831
Contact persons: Y. Antesary

ISRAEL:

►CONDOR-AVIATION INDUSTRIES LTD.

P.O. Box 1903, 14 Topaz st.
Cesaria 38900
Tel.: 06 / 6265080, 90 / 50-290189
Fax: 06 / 62650 95
E-mail: condor@netvision.net.il
Contact person: David Viernik

J A P A N :

►JUA, LTD.

1793 Fukazawa, Gotemba City
SHIZUOKA PREF 412
Tel.: 550 / 83 8860, Fax: 550 / 83 8224
Contact person: Yoshihiko Tajika, President

KOREA:

►HWA YOUNG MEDICAL & SCIENCE CO.

Office address:
401 KeumKang Building
1439-1, Seocho 1 dong, seocho-ku, SEOUL 137-
071
Tel.: 02 / 3472-0271-5,
Fax: 02 / 3472-0276 (02/3471-4753)
Contact person: John Lee, President
Mailing address:
SL Kang Nam
P.O. Box 918, SEOUL

PAPUA NEW GUINEA:

► **BERT FLOOD IMPORTS PTY. LTD.**

P.O. Box 61, LILYDALE, VICTORIA 3140
AUSTRALIA
Tel.: 03 / 9735 5655, Fax: 03 / 9735 5699
E-mail: flood@smart.net.au
Contact person: Bert Flood

UNITED ARAB. EMIRATES:

► **AL MOALLA**

P.O. Box 7787
ABUDHABI
Tel.: 2 / 723 248, Fax: 2 / 788 073
E-mail: almoalla@emirates.net.ae
Contact person: Hussain Al Moalla

14) Warranty

14.1) Warranty Conditions / Warranty Card

1) Period

ROTAX[®] as manufacturer, warrants through their authorized ROTAX[®] distributors **FROM THE DATE OF SALE TO THE FIRST CONSUMER**, every ROTAX[®] non-certified aircraft engine, sold as **NEW AND UNUSED**, and **delivered by an authorized ROTAX[®] distributor** for a period of the earliest of:

- ✈ 6 consecutive months for private use owners
- ✈ or 12 consecutive months from date of shipment of the manufacturer
- ✈ or the first 100 operation hours.

2) What an authorized ROTAX[®] distributor will do

The authorized ROTAX[®] distributor will, at its option, repair and/or replace components defective in material and/or workmanship under normal use and service, with a genuine ROTAX[®] component without charge for parts or labour, during said warranty period. All parts replaced under warranty become the property of ROTAX[®].

3) Condition to have warranty work performed

You must present to an authorized ROTAX[®] service-center, the hard copy of the ROTAX[®] warranty registration card and/or proof of purchase delivered to the customer from the selling dealer at time of purchase.

4) Exclusions - are not warranted

- ✈ Normal wear on all items
- ✈ Replacement parts and/or accessories which are not genuine ROTAX[®] parts and/or accessories.
- ✈ Damage resulting from the installation of parts other than genuine ROTAX[®] parts.
- ✈ Damage caused by failure to provide proper maintenance as detailed in the Operator's Manual. The labour, parts and lubricants costs of all maintenance services, including tune-ups and adjustments will be charged to the owner.
- ✈ Aircraft engines designed and/or used for racing or commercial purposes.
- ✈ All optional accessories installed on the aircraft engine (The normal warranty policy for parts and accessories, if any, applies).
- ✈ Damage resulting from running the aircraft engine without propeller.
- ✈ Damage resulting from modification to the aircraft engine not approved in writing by ROTAX[®].
- ✈ Damage caused by electrolysis.
- ✈ Cold seizure and piston scuffing.
- ✈ Use of a gear reduction not designed by ROTAX[®].
- ✈ Use of propellers which exceed the inertia and balance limits as specified by ROTAX[®].
- ✈ If engine instruments recommended by ROTAX[®] have not been installed.
- ✈ Losses incurred by the aircraft engine owner other than the parts and labour, such as, but not limited to, mounting and dismounting of the engine from the aircraft, loss of use, transportation, towing, telephone calls, taxis, or any other incidental or consequential damage.
- ✈ Damage resulting from accident, fire or other casualty, misuse, abuse or neglect.

- ☞ Damage/rust/corrosion premature wear to the engine caused by water ingestion.
- ☞ Damage resulting from sand/stones infiltration.
- ☞ Damage resulting from any foreign material ingestion.
- ☞ Damage resulting from service by an unqualified mechanic.

5) Expressed or implied warranties

This warranty gives you specific rights, and you may also have other legal rights which may vary from state to state, or province to province. Where applicable this warranty is expressly in lieu of all other expressed or implied warranties of ROTAX®, its distributors and the selling distributor, including any warranty of merchantability or fitness for any particular purpose; otherwise the implied warranty is limited to the duration of this warranty. However, some states or provinces do not allow limitations on how long an implied warranty lasts, so the above limitation may not apply.

Neither the distributor, nor any other person has been authorized to make any affirmation, representation or warranty other than those contained in this warranty, and if made, such affirmation, representation or warranty shall not be enforceable against ROTAX® or any other person.

ROTAX® reserves the right to modify its warranty policy at any time, being understood that such modification will not alter the warranty conditions applicable to aircraft engines sold while the above warranty is in effect.

6) Consumer assistance procedure

If a servicing problem or other difficulty occurs, please contact:

- ☞ authorized ROTAX® service-center or
- ☞ authorized ROTAX® distributor.

7) Validity:

Warranty will only be valid if the end user completes this registration card as soon as the aircraft engine goes into service, and returns it to the national authorized ROTAX® distributor (marked with "►" in section Distributors) of the area in which the aircraft engine is firstly operated.

This warranty will be effective for all non-certified aircraft engines delivered by BOMBARDIER- ROTAX as of June 1st, 1992.

8) Danger!

This engine, by its design, is subject to sudden stoppage! Engine stoppage can result in crash landings. Such crash landings can lead to serious bodily injury or death.

Never fly the aircraft equipped with this engine at locations, airspeeds, altitudes, or other circumstances from which a successful no-power landing cannot be made, after sudden engine stoppage.

Aircraft equipped with this engine should only fly in DAYLIGHT VFR conditions.

▲ WARNING!

This is not a certificated aircraft engine. It has not received any safety or durability testing, and conforms to no aircraft standards. It is for use in experimental, uncertificated aircraft and vehicles only in which an engine failure will not compromise safety.

User assumes all risk of use, and acknowledges by his use that he knows this engine is subject to sudden stoppage.



WARRANTY REGISTRATION CARD

Issue 99 05 01



1. To be eligible for warranty, this registration card must be returned completed and signed by the end user to the authorized ROTAX distribution partner (section 13) of the area of the permanent residence of the end user and / or in which the aircraft engine is firstly operated, within 30 days as of date of purchase.

2. No other warranties and/or guarantees than defined in the actual warranty conditions are made.

3. Engine type: ■ ■ ■

Engine no.:

Gearbox: Reduction i =

Inv.-no.: date of purchase:

Warranty expires:

Seller:

Buyer:

I have read and understood the operator's manual in its entirety and carefully followed the described break-in procedure.

Date: _____ Signature: _____



d00336



Postkarte
Carte postale

Mar
ke
Tim
bre

Postleitzahl - Code postal Bestimmungsort - Lieu de destination

Bestimmungsland - Pays de destination

DANGER!

This engine, by its design, is subject to sudden stoppage! Engine stoppage can result in crash landings. Such crash landings can lead to serious bodily injury or death.

Never fly the aircraft equipped with this engine at locations, airspeeds, altitudes, or other circumstances from which a successful no-power landing cannot be made, after sudden engine stoppage.

Aircraft equipped with this engine should only fly in DAYLIGHT VFR conditions.

WARNING!

This is not a certificated aircraft engine. It has not received any safety or durability testing, and conforms to no aircraft standards. It is for use in experimental, uncertificated aircraft and vehicles only in which an engine failure will not compromise safety. User assumes all risk of use, and acknowledges by his use that he knows this engine is subject to sudden stoppage.

Absender:
Expéditeur:

Postleitzahl - Code postal

03002

Effectivity: 447 SCDI, 503 DCDI,
582 DCDI



OM
initial issue

page 14 - 4
May 01/99

d00336

WARRANTY CARD

1. To be eligible for warranty, this registration card must be returned completed and signed by the end user to the authorized ROTAX[®] distribution partner (section 13) of the area of the permanent residence of the end user and / or in which the aircraft engine is firstly operated, within 30 days as of date of purchase.
2. No other warranties and/or guarantees than defined in the actual warranty conditions are made.
3. Engine type: ■ ■ ■

Engine no.:

Gearbox: Reduction:

Inv.-no.: date of purchase:

Warranty expires:

Seller:

Buyer:

I have read and understood the operator's manual in its entirety and carefully followed the described break-in procedure.

Date: _____ Signature: _____

14.2) Reporting

In case of a malfunction or a defect the form on the next page should be filled out and should be sent to the responsible ROTAX[®] authorized distributor.



Formblatt Nr. 17-058/A—98 11 11

OMB No. 2120-0003

 MALFUNCTION OR DEFECT REPORT <small>Enter pertinent data</small>		OPER. Control No.		
		ATA Code		
1. A/C Reg. No.		MODEL/SERIES		SERIAL NUMBER
2. AIRCRAFT				
3. POWERPLANT	ROTAX			
4. PROPELLER				
5. SPECIFIC PART (of component) CAUSING TROUBLE				
Part Name	MFG. Model or Part No.	Serial No.	Part/Defect Location	
6. ENGINE COMPONENT (Assembly that includes part)				
Engine/Comp. Name	Manufacturer	Model or Part No.	Serial Number	
Engine TSN	Engine TSO	Engine Condition	7. Date Sub.	

8. Comments (Describe the malfunction or defect and the circumstances under which it occurred. State probable cause and recommendations to prevent recurrence.)

Optional Information:
 Check a box below, if this report is related to an aircraft
 Accident: Date Incident: Date

REP. STA	OPER	MECH	AIR TAXI	MFG	ACG	COMPUTER	OTHER	DISTRICT OFFICE	OPERATOR DESIGNATOR	SUBMITTED BY: _____	TELEPHONE NUMBER: () _____
<input type="checkbox"/>	<input type="checkbox"/>	<input type="checkbox"/>	<input type="checkbox"/>	<input type="checkbox"/>	<input type="checkbox"/>	<input type="checkbox"/>	<input type="checkbox"/>	<input type="checkbox"/>	<input type="checkbox"/>		

The Sky is the LimitSM

ROTAX

AIRCRAFT ENGINES

FREUND Linz-austria

Motornummer
Engine serial no.

Flugzeugtype
Type of aircraft

Flugzeugkennzeichen
Aircraft registration no.

ROTAX® Vertriebspartner

ROTAX® authorized distributor